

# Thermal Modeling of High Voltage H. R. C. Fuses and Simulation of Tripping Characteristic

G. Hoffmann<sup>(1)</sup> and U. Kaltenborn<sup>(2)</sup>

ABB Switzerland Ltd, Corporate Research<sup>(1,2)</sup>, Segelhof 1, CH-5405 Baden-Dättwil, Switzerland,  
guido.hoffmann@ch.abb.com<sup>(1)</sup>, uwe.kaltenborn@ch.abb.com<sup>(2)</sup>

**Abstract:** The operation of a fuse is always a thermal process. To know the thermal behavior of a fuse is important for an optimized design as well as for the right choice of the fuse rating for each application. A model for a fuse based on the Thermal Network Methodology was developed, including terminals, electrical connections, and a fuse canister. In this model, the thermal behavior of a h.r.c. fuse is only dependent on the design of the fusing element, the material parameters, and the ambient conditions. The elements of the thermal network are based only on the geometry and the material properties of the different components. The simulated temperatures were compared with measured temperatures at defined positions of the fuse. By introducing the thermal capacitance as an additional material parameter, a time-dependent dynamic simulation becomes possible. It was shown that such a dynamic model allows a highly accurate simulation of the tripping characteristic of high voltage h.r.c. fuses.

**Keywords:** high voltage fuse, h.r.c. fuse, thermal simulation, thermal network

## 1. Introduction

The physical processes in a fuse are always initiated by the thermal behavior of the fuse in the specific application. In the electrical grid a fuse, or better the fuse element, is a defined reduction of the electrical conductor cross-section. This means an increase of the electrical resistance. Each resistance is corresponding to a certain electrical loss. Due to the fact that the impedance of a conventional fuse is very low, most of the electrical losses in fuses appear as thermal losses.

These thermal losses of the fuse element have to be forced away from the fuse element. This will happen along the fuse element and radial through the arc extinguishing medium and the housing. If the thermal losses produced in the fuse element and the heat flow away from the fuse element reaches equilibrium, the temperature of the fuse element will stay stable. As soon as the equilibrium is distorted in such a way that the heat flow away from the fuse element is less than the thermal losses, a thermal run away occurs. Due to the temperature dependency of the electrical resistance of metals, the resistance will increase with the temperature and therefore increase the thermal losses. This deadly spiral will continue until the melting point of the fuse element is reached and the fuse will trip.

To understand and to optimize the operating mechanisms of h.r.c. fuse links, the thermal behavior of the fuse itself and their application is of major interest. Having the opportunity to simulate the thermal processes at the fuse element dependent on the fuse design enables new features for the optimization of h.r.c. fuses. On the other hand, new

fuse designs can be evaluated for their thermal behavior. By introducing a dynamic model including thermal capacitances, also the tripping characteristic can be simulated. This will have a great impact to the development and test costs of new fuses.

Extending the model with thermal models for the specific applications enables the user of h.r.c. fuses to choose the right ratings and to evaluate critical load cycles and to identify potential overload capacities for a dynamic grid loading.

## 2. Fundamentals of the thermal network method

The thermal network method is based on the analogy between the electrical and thermal flow field [1-2], (Table 1).

**Table 1:** Analogy between electrical and thermal flow field

Electrical Parameter			Thermal Parameter		
Potential difference	$\Delta\varphi$	V	Temperature difference	$\Delta\vartheta$	K
Electrical current	$I$	A	Heat flow	$P$	W
Electrical resistance	$R_{el}$	$\Omega$	Thermal resistance	$R_{th}$	K/W
Electrical capacity	$C$	As/V	Heat capacity	$C_W$	Ws/K

Due to this analogy heat transport processes in electrical devices can be described with thermal networks, which consists of heat sources, thermal resistances, and heat capacities.

As the thermal resistances, the heat capacities and heat sources are temperature-dependent the

resulting thermal network is nonlinear. The networks will iterative calculated by using the nodal point procedure known from electrical network calculations. That means thermal networks can be solved with common network analysis programs like PSpice or SIMplorer [2-3].

### 3. Structure of the thermal networks

For every individually device like the h.r.c fuse itself, the fuse mounting, the fuse canister for ring main unit installations or the connecting cables, separate thermal networks were designed. These networks are comparable with modules, which can be easily connected together by defined nodes.

In thermal networks the heat sources like the fuse wires, the contacts, and the conducting parts of the fuse mounting will be simulated as electrical resistors, which are temperature- and current-dependent. The heat conduction in the fuse in radial direction to the surface of the ceramic tube or in axial direction to end caps as well as the convection to the ambient air and the radiation to ambient (free air) or to an opposite surface (canister) were modelled with corresponding thermal resistors in the network.

All necessary simulation parameters for the network elements (resistors for heat conduction, radiation and convection and heat capacity) result from the geometry and the different material properties of the fuse.

For the creation of the thermal networks the fuse as well as the fuse canister will be discredited into different parts, i.e. the fuse into end caps and several slices of the middle part (tube).

The modelling of the fuse with the thermal network method will be shown with simplified networks on following examples:

- Simulation of the fuse wire
- From the fuse wire to outer surface
- End caps and fuse terminal
- Canister

The thermal networks were created with the SCHEMATICS-GUI and solved with the PSpice-solver<sup>1</sup>. The elements for the thermal processes where used from a thermal library available from THETA<sup>2</sup>, and own extensions.

#### 3.1. Simulation of the fuse wire

The heat source in a fuse is the conducting fuse wire. In case of common medium voltage fuses this

fuse wire is made of silver. For different nominal current ratings you will find a different number and different dimensions of fuse wires wounded around a ceramic star-shaped stick in the fuse.

Normally a single fuse wire consists of a silver band with several constrictions for the arc extinction in case of short-circuit-currents. These constrictions can have different shapes, for the present model the constriction has semicircular punched areas on both sides.

Every flow of current through a silver wire will produce power losses:

$$P = kI^2 R(\vartheta) \quad (1)$$

The power losses depends on the current displacement factor  $k$ , the squared current  $I^2$  and the electrical resistance  $R(\vartheta)$ . This temperature-dependent resistance can be calculated by

$$R(\vartheta) = \frac{\rho_{20} l}{A} \left[ 1 + \alpha_T (\vartheta - 20^\circ\text{C}) + \beta_T (\vartheta - 20^\circ\text{C})^2 + \gamma_T (\vartheta - 20^\circ\text{C})^3 + \delta_T (\vartheta - 20^\circ\text{C})^4 \right] \quad (2)$$

with:

$$\rho_{20} = 0.017961 \frac{\Omega\text{mm}^2}{\text{m}}$$

$$\alpha_T = 9.623 \cdot 10^{-4} \frac{1}{\text{K}}; \quad \beta_T = 1.277 \cdot 10^{-5} \frac{1}{\text{K}^2}$$

$$\gamma_T = -1.908 \cdot 10^{-8} \frac{1}{\text{K}^3}; \quad \delta_T = 1.013 \cdot 10^{-11} \frac{1}{\text{K}^4}$$

where  $\rho_{20}$  is the resistivity of the silver wire at  $20^\circ\text{C}$  and  $\alpha_T$ ,  $\beta_T$ ,  $\gamma_T$ , and  $\delta_T$  are the thermal coefficients describing the temperature dependency.

Normally only  $\alpha_T$  will be used for a linear increase of the resistivity with the temperature. Because the heat source element in the thermal library is programmed to use the four coefficients the resistivity curve was fitted in this way.

This also increases the simulation accuracy in the range of higher temperatures where the resistivity doesn't follow the linear increase of only one coefficient. The high temperature range is especially important for simulation of the pre-arcing time because there the accuracy up to the melting point of the silver wire is needed.

To simulate the heat source, i.e. for the dimensioning of the melting wire, it is necessary to consider the geometry of the fuse wire, especially the constrictions of the fuse wires, which has to be implemented into the calculations.

There are different possibilities like FEM simulations to calculate the electrical resistance of the constriction, but [4] describes an easy to use empirical method for the calculation of the

<sup>1</sup> OrCAD PSpice and Schematics Version 9

<sup>2</sup> Ingenieurbüro Theta (Dresden/Germany)

resistance-change of a fuse wire with one or more constrictions.

The parameter of the constriction coefficient  $E$  will be introduced, which is independent from dimension and the material of the fuse wire. The constriction coefficient could be applied to all sections of wires with a particular geometric base. It is a function of the base figure.

Wire sections with a number of constrictions for the limitation of high current arcs and with a shape of circles (Fig. 1) can be calculated with [4]:

$$E = \frac{\pi}{2} \left( \sqrt{\frac{r}{e}} \cdot \arctan \sqrt{\frac{r}{e} - \frac{r}{b}} \right) \quad (3)$$

where  $r$  is the radius of the semi-circular holes in the fuse wire,  $e$  is half of the constriction width, and  $b$  is half of the fuse wire width.

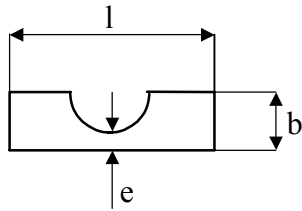

**Fig. 1:** Section of a fuse band with a constriction

Now the resistance of melting wire with changed cross section can be calculated as follows:

- Melting band with one constriction

$$R_l = \left( 1 + E \frac{b}{l} \right) R_0 \quad (4)$$

- Melting band with  $n$  constrictions:

$$R_l = \left[ 1 + (E_1 + E_2 + \dots + E_n) \frac{b}{l} \right] R_0 \quad (5)$$

$R_1$  is the resistance of a wire section with one or more constrictions and  $R_0$  is the resistance of a wire section without constrictions. Both wire sections have the same length.

The relation  $R_1/R_0$  is a factor for the increase of the resistance by the constrictions.

For the simulation of the heat source, the fuse wire was disassembled into 2 parts.

- a homogeneous part (plane wire without constrictions) of the fuse wire with a constant cross section.
- a second part of the fuse wire with all constrictions

From the relation of the lengths of these two different parts of the fuse wire the same relation of the electrical resistances can be calculated.

With these both resistances two heat sources can be created. Because there is the possibility to add a current displacement factor in the heat source element this is an easy way to regulate the influence of the constrictions. For the homogeneous part of the melting wire the current displacement factor is 1. For the part of the fuse wire with constrictions it will be larger than 1 depending on the geometry and can be calculated with the above equations (4), (Fig. 2).

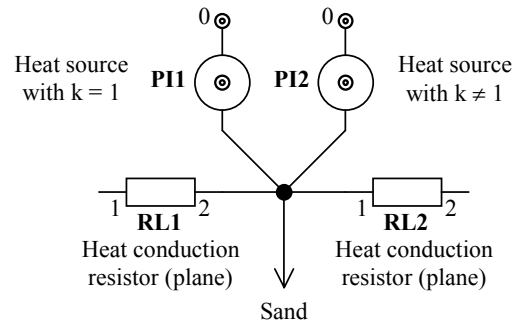

**Fig. 2:** Simulation of the melting wire with two different heat sources

It is of course also possible to use only one heat source for the fuse wire instead of two. This one heat source will generate the same amount of energy and will lead to the same simulation results.

### 3.2. From the fuse wire to outer surface

For the simulation the fuse will be cut into several slices of the same thickness. Fig. 3 shows for one slice the radial heat transfer with the radial heat conduction in the fuse sand, the radial heat conduction in the ceramic tube, and the heat radiation and convection at the surface of the fuse. The slices will connect axial with thermal conduction resistors. The connection point is situated in the middle of a coaxial section for the fuse sand and the ceramic tube. There is also the connection point for the heat capacity.

The parameters of the elements (heat capacity, plane/coaxial heat conduction resistor, heat radiation/convection resistor) result only from the geometry and the material properties of the fuse.

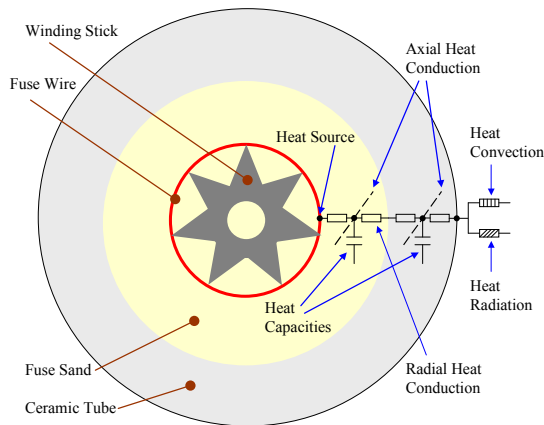
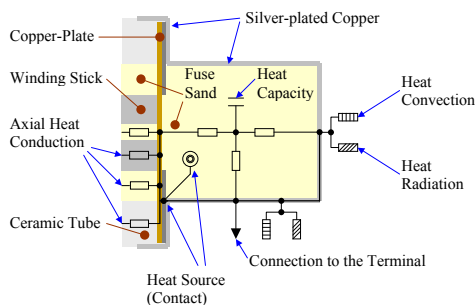

**Fig. 3:** Heat transfer from the heat source (fuse wire) to the surface of the fuse

This sub-network was reused, because the material properties for the calculation of the heat capacities and the geometric dimensions of the heat conduction resistors of the fuse sand and the winding stick are the same in every slice of the fuse.

Only the thermal conductivity of the fuse sand must be defined for the sub-network because it is not constant. The thermal conductivity of the fuse sand is dependent on the temperature, so it will vary from the melting wire to the inner side of the ceramic tube as well as from the middle of the fuse to the end caps.

### 3.3. End caps and fuse terminal

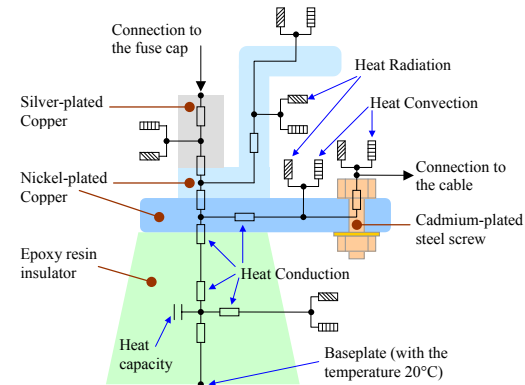

**Fig. 4:** Schematic thermal network of the fuse end cap with a heat source (wire-cap contact)

Fig. 4 shows only a rough schematic circuit of the fuse caps. The real structure of the thermal network in the simulation is considerably more detailed. The axial heat conduction of the fuse sand, the winding stick and the ceramic tube consists of several thermal elements. For each part there are two plane heat conduction resistors, two coaxial heat conduction resistors and a heat capacity. The copperplate has two heat conduction resistors and a heat capacity; the contact to the heat source has also two heat conduction resistors.

The silver-plated copper cap was cut into four sections. All sections are connected together with heat conduction resistors and have their own heat convection and heat radiation resistors according to the surfaces. One of these sections contains the connection to the terminal. Of course the contact surface of this connection is not an operative surface for heat transfer by convection or radiation.

Also this part was created as a reusable sub-network. Only one parameter, the thermal conductivity of the fuse sand, can differ between both sides and will be defined externally.



**Fig. 5:** Schematic thermal network of the terminal

Fig. 5 shows a simplified schematic thermal network of the terminal. The metal parts (nickel-plated copper) of the terminal have a lot of different surfaces, e.g. vertical and horizontal surfaces for heat release upward and downward. Therefore it was necessary to cut the metal parts of the terminal into sections with different kinds of surfaces.

The emission coefficients of the different surfaces (silver-plated copper, nickel-plated copper, cadmium-plated steel and epoxy resin) as well as the thermal conductivity and the specific heat capacity were measured or taken from literature [1-5-6-7]. The emission coefficients of the cadmium-plated screw and the silver-plated copper were measured with an infrared camera. Therefore samples of both plated materials were heated and the temperature was measured with a thermocouple as reference and the infrared camera system. The emissivity in the camera was adjusted up the point where the reference temperature was reached.

The temperature of the base plate at the bottom of the insulator was assumed to be the same as the ambient temperature.

### 3.4. Fuse Canister

The previously developed thermal network model of the fuse was extended by a separate model of the fuse canister. It can be easily applied to other rated fuses or be implemented in larger models like a complete switch-gear (Fig. 6).

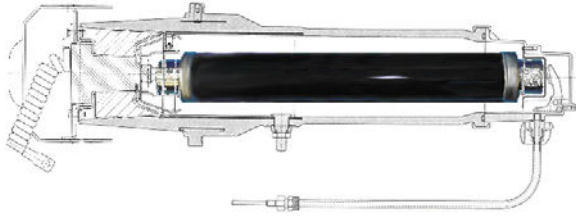

Fig. 6: Fuse in canister (schematic)

The canister was split into 6 main sections based on the geometry (Fig. 7). Each of the 6 main sections is separated into a number of sub-sections, which were connected to the model of the fuse.

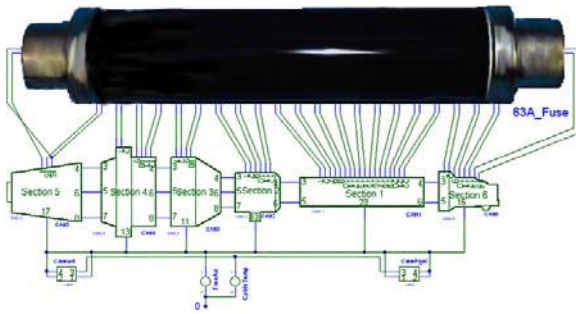

Fig. 7: Schematic of different canister parts in the thermal network

The heat transfer between the fuse and the canister and the radiation and convection outside the canister was taken into account.

For comparison with the measurements it was assumed in the simulation that the canister is placed in free air and not in a switchgear.

### 4. Results of the simulation

The values of the measured temperatures are averages of three experimental runs with self-assembled fuses and two experimental runs with a serial fuse. The self-assembled fuses were prepared with thermocouples on the wire, the winding stick, the inner ceramic tube, the contacts, and the surface of the fuse. The fuse from the serial production was prepared with thermocouples on the surface of the fuse, the terminal, and the connections to the cables. For comparison all measured values were normalized with the ambient temperature to 20°C.

### 4.1. Static simulation results at steady state

According to IEC 60282-1, the steady state of the temperature values is defined as the point where the temperature rise is less than 1 K during one hour. All temperature-rise tests ran over five hours and fulfilled the criterion for steady state.

For the free air steady state comparison all measurements and simulation results are related to the nominal current of the fuse (normal operating conditions). For the comparison of the simulated and measured temperatures of the fuse in the canister the de-rated current was used.

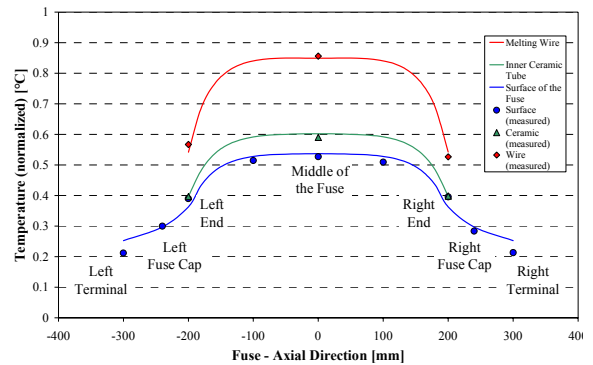

Fig. 8: Steady state axial temperature distribution of the fuse with terminals (free air)

The simulated temperatures match very well with the measured values (Fig. 8). Smaller deviations can be seen for the terminals. Here the networks for the cable and the terminal networks are not so detailed discretized compared to the fuse, due to the fact that the main interest was on a good model with high accuracy of the fuse.

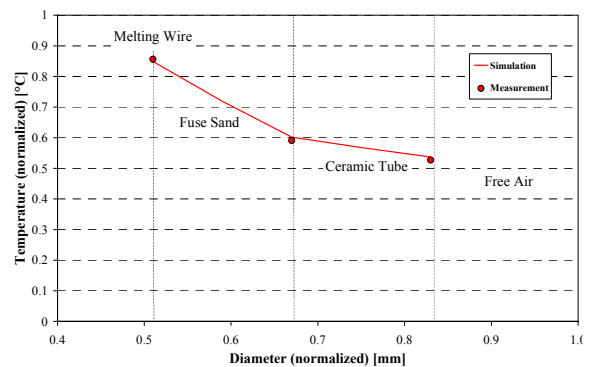
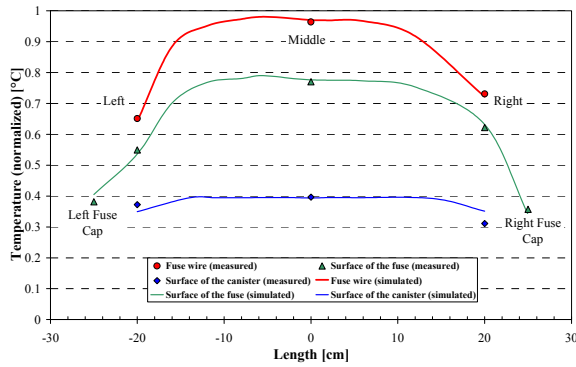

Fig. 9: Radial temperature distribution at the middle of the fuse

Especially at the middle section of the fuse, where the hottest region is located, a very good consistency of the measured and simulated

temperatures (Fig. 9) was reached. This high accuracy is necessary to gain acceptable results for the dynamic simulation of the pre-arcing time.

The same simulations up to the steady state point were made for the fuse mounted in a fuse canister. The corresponding de-rated current was used; like the current in switchgears for transformer protection (Fig. 10).



**Fig. 10:** Steady state axial temperature distribution of the fuse in the canister

The static simulations of the fuse in the canister showed also a very good accordance between simulated and measured data, especially again in the middle of the fuse/canister (Fig. 11).

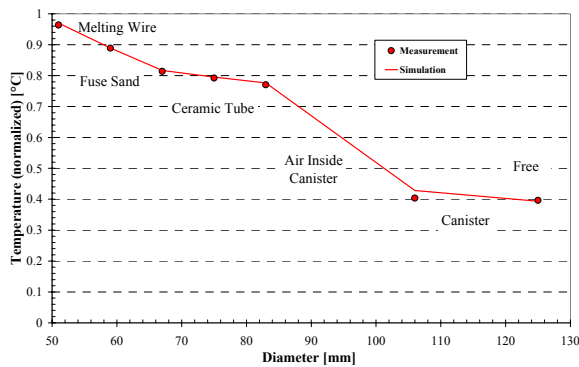

**Fig. 11:** Steady state radial temperature distribution at the middle of the fuse

This model of a fuse-canister combination can be further used as a separate part for the simulation of complete switchgears.

#### 4.2. Dynamic simulation results

By adding heat capacity elements, which are only dependent on the volume, the density and the specific heat capacity of the material, to the existing static models the thermal networks become dynamic and can be simulated time dependent.

This feature opens a lot of different opportunities of simulations shown in the next examples.

The heating up of the fuse at nominal conditions can be simulated (Fig. 12). Influences on the steady-state-temperature and -time like material or fuse wire changes; changes on the contacts etc. can be easily estimated.

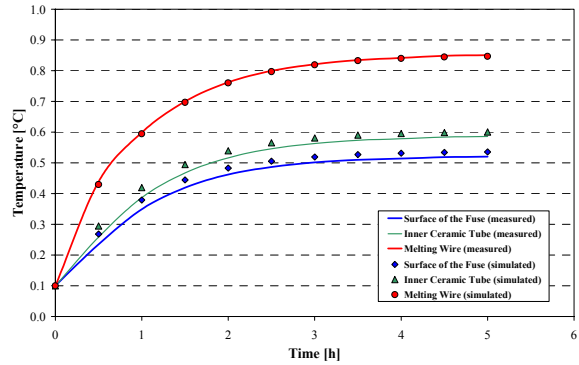

**Fig. 12:** Dynamic behaviour at the middle of the fuse (free air)

Another option is the simulation of the pre-arcing-time of the fuse; the time up to the melting temperature of the silver fuse wire (Fig. 13).

The current can be an over-current with a typical hot spot region in the middle of the fuse as well as a short circuit current with adiabatic heat up of all constrictions.

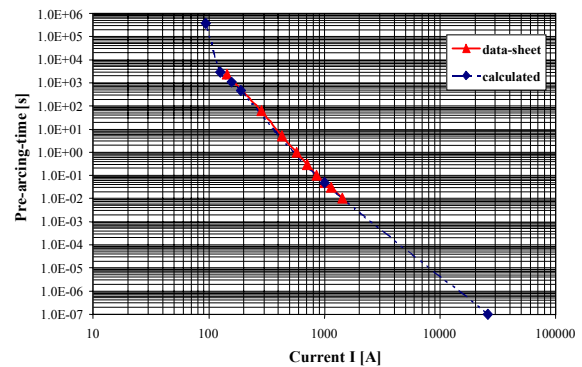

**Fig. 13:** Dynamic behaviour – pre-arcing time

Especially for higher over-currents and short-circuit currents a very good consistency with data sheet values was reached.

The M-effect, provoked by a low melting metal or alloy on the silver fuse wire, which starts a diffusion process at low over-currents and leads to a thermal runaway and tripping of the fuse, was not taken into account in this simulation. That means that the I-t-characteristic in this region of lower over-currents will not be exact simulated.

A third example is the dynamic simulation of the complete fuse-canister combination under the aspect of the dependent reaction of the different components on load peaks.

Fig. 14 shows the dynamic behavior of the fuse-canister combination for a defined typical load curve over a day. There the maximum current is related to the de-rated current of the fuse-canister combination for a transformer application.

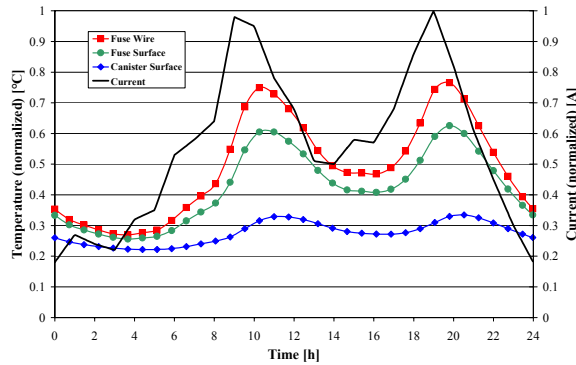

**Fig. 14:** Dynamic behaviour of a fuse and canister for a typical daily load curve

By expanding this thermal network of a fuse-canister combination to a complete switchgear-model, it becomes possible to estimate the overload capacity of the system.

Especially the demands for short time overloading of the system can be fulfilled if the load curve over the day and the ambient conditions are known. The temperature distribution and time characteristic can be calculated. Dependent on the difference to the maximum allowed temperatures a prediction about the overload capacity and reserves of the system can be made.

## 5. Conclusion

A dynamic electro-thermal simulation based on the thermal network methodology was evaluated for a h.r.c fuse used in free air or in combination with a fuse canister for switchgears. From the fuse itself and additional parts like the free air mounting or the fuse-canister, structured models were developed to simulate different combinations and larger systems like complete switchgears.

Static simulations of the fuse were done with a very high accuracy. The static simulation was extended to a complete model of a fuse in a canister for switchgear applications. By including thermal capacitances in these models a dynamic simulations became possible. The dynamic model was verified with a simulation of the heating-up time up to steady state conditions and with a simulation of the pre-arcing time of a standard fuse.

It was shown that the described thermal network simulation shows a high potential for a variety of different applications:

- Development support
- Identifying user risks
- Evaluating the right de-rating current
- Evaluating overload capacity without destructive failure of the fuse

## References

- [1] Böhme H.: "Mittelspannungstechnik". Verlag Technik 1992.
- [2] Kessler A.: "Zur Theorie des Wärmequellennetzes". *Archiv für Elektrotechnik*, Vol 49, No 2, 1964, pp. 109-123.
- [3] Schenk M., Löbl H.: "Strombelastbarkeit und Erwärmung der Geräte in Netzstationen". *Elektrizitätswirtschaft*, Vol 99, No.15, 2000, pp.23-31.
- [4] Johann H.: "Elektrische Schmelzsicherungen für Niederspannung: Vorgänge, Eigenschaften, technischer Einsatz". Springer-Verlag 1982.
- [5] Verein Deutscher Ingenieure (Ed.): "VDI-Wärmeatlas: Berechnungsblätter für den Wärmeübergang". 8<sup>th</sup> rev. Edition, Springer-Verlag 1997.
- [6] Smithells C. J.: "Metals Reference Book". 5th Ed. London & Boston: Butterworths, 1976.
- [7] CRC Handbook of Chemistry and Physics. 78th Ed. Boca Raton; New York: CRC Press, 1998.